

Operation Manual for LFW Series Wall-Mounted Battery

Product model:

LFW51100/LFW51200/LFW48100

File version: V1.1

Revision history

number	Version	Amendments	Revision date	Establishment
1	V1.0	First edition	2023/12/19	
2	V1.1	Add product information for model LFW48100	2024/01/17	

Contents

1、 Safety instructions	4
2、 Introduction to the basic functions of LFW series wall-mounted batteries	9
3、 Structure and Function Description of LFW Series Wall-Mounted Batteries	12
4、 Installation and usage instructions for rack batteries	15
5、 Screen operation instructions	30
6、 Storage instructions	38
7、 Declaration	38

1、 Safety instructions







Danger: Non-compliance with prescribed operating procedures may lead to the occurrence of incidents such as fire, severe bodily harm, or even fatalities.





Attention: Non-compliance with prescribed operating procedures may cause moderate or minor personal injury, as well as system failure or damage. When installing, using, and repairing this system, please read this manual carefully and be sure to follow the safety precautions required in this chapter! Any injury or losses caused by non-compliance with operating instructions are not the responsibility of our company!

Usefulness	Danger
	<ul style="list-style-type: none"> ◆ This series of battery packs must be used together with the compatible inverter, otherwise it may cause system damage. ◆ This series of battery packs is used for energy storage and cannot be used for other purposes, as it may cause system malfunctions or fires.
Arrival inspection	Attention
	<ul style="list-style-type: none"> ◆ If system components are found to be

	<p>damaged, do not proceed with the installation. Please communicate promptly with and confirm with the manufacturer in a timely manner, otherwise it may affect the project application.</p> <ul style="list-style-type: none"> ◆ If it is found that the packing list does not match the physical name, communicate and confirm with the manufacturer in a timely manner, otherwise it may affect the project application.
Install	<p> Attention</p>
	<ul style="list-style-type: none"> ◆ When handling and installing, please handle with care, otherwise it may cause system damage. ◆ This system should be kept away from flammable and explosive materials and heat sources.
Assembly wiring	<p> Danger</p>
	<ul style="list-style-type: none"> ◆ Installation must be guided by qualified electrical engineering personnel who are familiar with the system, otherwise there is a risk of electric shock or damage to the system. ◆ Before wiring, it is necessary to ensure

	<p>that the power supply is disconnected, otherwise there is a risk of electric shock or fire.</p>
	<p> Attention</p>
	<ul style="list-style-type: none"> ◆ Confirm if the communication wiring is correct, otherwise it may cause abnormal operation ◆ Confirm whether the positive and negative pole connections of the power supply are correct, otherwise it may cause system damage.
<p>Running</p>	<p> Danger</p>
	<ul style="list-style-type: none"> ◆ Only after proper connection can the power be turned on. It is strictly prohibited to plug and unplug the wiring harness when the power is on, otherwise there is a risk of electric shock. ◆ Non system familiar professionals are not allowed to change the parameters of the upper computer settings page without authorization, otherwise it may cause system malfunctions or even accidents.
	<p> Attention</p>

	<ul style="list-style-type: none"> ◆ Before running, please confirm whether this system is within the allowable range of use, otherwise it may cause damage to the system. ◆ Before operation, please confirm that the positive and negative wiring screws are tightened, otherwise it may cause system damage
<p>Maintenance inspection</p>	 Danger
	<ul style="list-style-type: none"> ◆ If you want to disassemble the casing, please ensure the power is disconnected, otherwise there will be a risk of electric shock. ◆ Please designate qualified electrical engineering for maintenance, inspection, or replacement of components to prevent accidents.
	 Danger <ul style="list-style-type: none"> ◆ Do not squeeze, puncture, drop, vibrate, heat or short-circuit, and keep away from corrosive substances. ◆ Do not disassemble the battery by yourself. Incorrect disassembly can cause short circuits and other problems such as fire, gas, and even explosion;

Others	<ul style="list-style-type: none">◆ Do not place the battery in a fire. Otherwise, it may cause very dangerous situations such as fire and explosion.
	 Attention
	<ul style="list-style-type: none">◆ If deformation, swelling, leakage or other issues are found, please do not use.◆ Do not place the battery in substances such as water or liquids.

2 、 Introduction to the basic functions of LFW series wall-mounted batteries

This is a lithium battery pack installed in a wall-mounted form, which can be combined with an adaptive inverter to form a household energy storage system. AC mains electricity (or solar energy generated through photovoltaic panels) is converted into appropriate voltage range DC electricity through an inverter to charge the battery pack and store electrical energy for use when needed. During the use of the product, the electrical energy of the lithium battery pack is converted into alternating current (grid connected or off grid, depending on user needs and inverter functions) through an inverter to supply power to the user's electrical equipment

The appearance of the LFW series wall-mounted battery products is shown in Figure 1



Figure 1: Appearance of LFW wall-mounted series products

Application scenarios of LFW series wall-mounted batteries, as shown in Figure 2

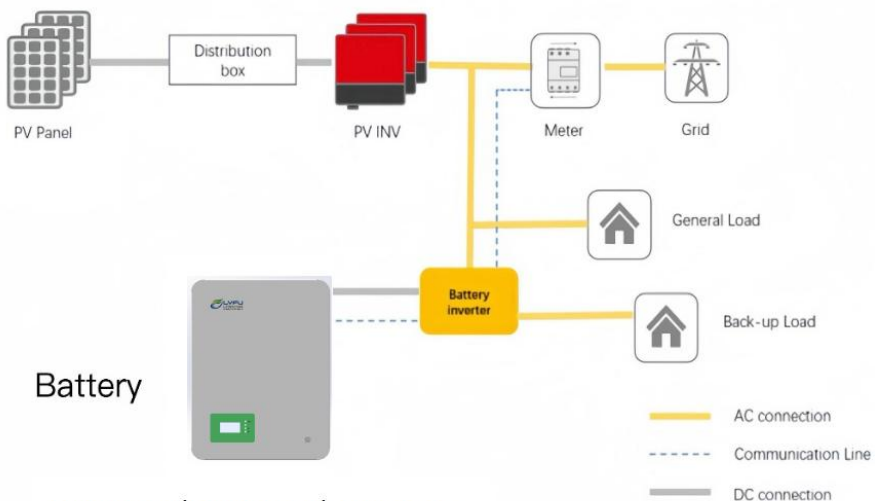

LFW48100/LFW51100/LFW51200

Figure 2: Application scenarios of LFW series wall-mounted batteries

Table1 LFW series wall-mounted battery models and their technical parameters

Type		LFW-51100	LFW-51200	LFW-48100
Product Specification		51V100Ah	51V200Ah	48V100Ah
Parameters	battery type	LiFePO4		
	nominal voltage (V)	51.2	51.2	48
	Charging voltage range (V)	44-57.6	44-57.6	41.5-54
	Charge float voltage(V)	54	54	51
	Max charge voltage(V)	57.6	57.6	54
	Charging current reduction opening conditions	Total voltage \geq 56V	Total voltage \geq 56V	Total voltage \geq 52.5V
		Or cell voltage \geq 3.5V		
	Charging current reduction value	\leq 10A		

	Charging cutoff (V)	57.6	57.6	54
		Or cell voltage ≥ 3.63		
	Maximum charging/discharging current(A)	50/100	100/100	50/100
	Discharge cut-off voltage (V)	SOC $\leq 15\%$, Or		
		Total voltage ≤ 46.4	Total voltage ≤ 46.4	Total voltage ≤ 43.5
		Or cell voltage ≤ 2.9		
Rated battery capacity(Ah)	100Ah	200Ah	100Ah	
Rated battery energy (kWh)	5.12	10.24	4.8	
General characteristics	dimensions (W*D*H) $\pm 1.2\text{mm}$	600*423*203	600*423*266	600*423*203
	Battery pack weight(kg) $\pm 3\text{kg}$	55	90	55
*The rated battery capacity represents the discharge current at 0.5 C at $25 \pm 5^\circ \text{C}$ and 0.5 C at the cut-off state after 30 min of rest				

3 、 Structure and Function Description of LFW Series

Wall-Mounted Batteries

The LFW series wall-mounted batteries come in three specifications: 5.12kWh, 10.2kWh, and 4.8kWh. The front of the three specifications of wall-mounted batteries is a display screen and button switch, and the lower connector surface is the positive power supply end, negative power supply end, SOC indicator light, status indicator light, dry contact interface, reset switch, manual dial key, and parallel communication. As shown in Figure 3, Table 2

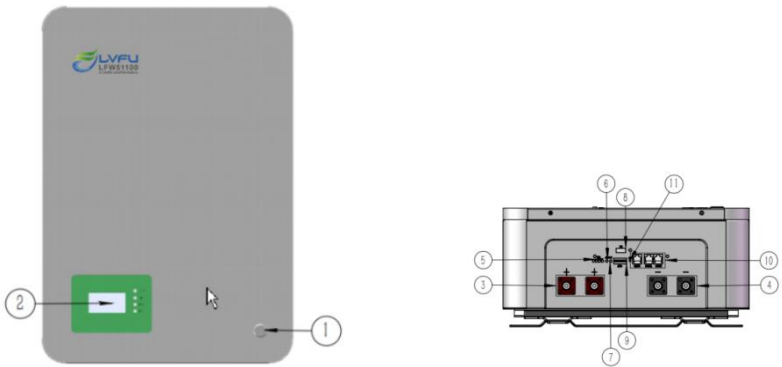

Fig 3

Table 2. Wall-mounted battery interface details

ref	Interface device	Silk screen identification	Function Description
1	Self locking button	\	Startup and shutdown

2	switch Display screen	LCD	Display battery operation and alarm information
3	Positive terminal	+	Battery positive output terminal
4	Negative terminal	—	Battery negative output terminal
5	Battery energy indicator	SOC	Display battery capacity status
6	Alarm indicator light	ALM	Display alarm status
7	Running indicator	RUN	Display running status
8	DRY contact	I/O	Output electrical signal (reserved)
9	DIP switch	ADDR	Set RS485 communication address
10	Communication interfaces	CAN、RS485A、RS485B	RS485A and RS485B are used for parallel communication, while CAN is used for communication with inverters (RS485 is optional)
11	Reset switch	RST	Control the startup and shutdown of BMS

4、 Installation and usage instructions for rack batteries

4.1 open boxing inspection

After opening the packaging box, check whether the goods are complete according to the goods packaging list in this document, inspect the appearance of the battery pack, and confirm the integrity and correctness of the equipment; Check if the battery case is deformed or corroded.

LFW51100 battery packing list:

LFW51100 battery pack × 1 unit

wiring × 1 set (including 25 square 0.8m positive electrode wires)

× 1. 25 square 0.8m negative electrode wire × 1. 0.4m grounding wire

× 1. 0.8m Ethernet cable × 1)

instructions × 1 book (this product)

Expansion screws × 7

LFW51200 battery packing list:

LFW51200 battery pack × 1 unit

wiring × 1 set (including 35 square 0.8m positive electrode wires)

× 1. 35 square 0.8m negative electrode wire × 1. 0.4m grounding wire

× 1. 0.8m Ethernet cable × 1)

instructions × 1 book (this product)

Expansion screws × 7

LFW48100 battery packing list:

LFW48100 battery pack × 1 unit

- wiring × 1 set (including 25 square 0.8m positive electrode wires)
- × 1. 25 square 0.8m negative electrode wire × 1. 0.4m grounding wire
- × 1. 0.8m Ethernet cable × 1)

instructions × 1 book (this product)

Expansion screws × 7

4.2 Precautions before installation

(1) Before installing the battery module, it is necessary to carefully check whether the open circuit voltage of the battery is normal, and whether there is any damage to the shell, leakage, or other phenomena;

(2) During the installation process, insulated tools and gloves should be used. Metal containing conductors such as watch bracelets should be removed from the wrist to prevent electric shock or short circuits between the positive and negative poles;

(3) The installation location of the battery should be far away from heat sources or areas prone to metal sparks, with a safe distance of more than 0.5m;

(4) Cannot connect batteries of different models, performance, and manufacturers together for use;

(5) The connection wires for battery pack installation should be as short as possible to prevent excessive line losses.

(6) Batteries should be kept away from direct sunlight and should not be placed in environments with a large amount of radioactivity, infrared radiation, organic solvent gases, and corrosive gases. They should be kept away from windows, air conditioning, exhaust fans, etc.

4.3 Installation steps:

4.3.1 Single machine use

(1) Before installing the battery, please ensure that the system end battery switch is in the OFF state to prevent ignition during installation and wiring.

(2) Keep the battery in a non working state (indicator light not on)

(3) Connect the negative terminal (P -) of the battery to the negative terminal of the system using a wire

(4) Connect the battery positive pole (P+) to the system positive pole using a wire.

(5) Connect the CAN/232 interface of the battery to the communication port of the inverter using a communication cable

(6) After the installation of the battery system, pay attention to the insulation treatment of the battery poles and cover the insulation cover

4.3.2 Parallel use

(1) If parallel connection is required, before conducting parallel connection, please check the voltage of each battery module. The voltage difference between battery modules should be less than 2V. If it is greater than this value, please adjust the voltage through charging and discharging and let it stand for at least 15 minutes before proceeding with the operation.

(2) The product supports a maximum of 16 parallel units for use

(3) The parallel connection method is as follows:

Parallel connection of power lines: Use wires to connect one positive

pole of the battery to another positive pole, and the negative pole to another negative pole. Series connection of wires between batteries are prohibited.

Communication cable cascading: Connect the RS485A interface on the panel to the previous RS485B interface through communication cables.

(4) Dialing address selection (manual dialing method)

Definition of parallel DIP switch: In multi machine communication when the battery pack is in parallel, the DIP switch is used to distinguish different pack addresses, and the hardware address can be set through the DIP switch on the board.

Definition of dial switches bit1 to bit8: bit1 to bit4 are used to set the address, and bit5 to bit8 are used for the number of slaves.

Host settings: Bit1 to Bit4 are set to 0, the host address is fixed to 0, and Bit5 to Bit8 are set based on the number of parallel slaves.

(As shown in Table 3)

Slave settings: Bit1 to Bit4 are set according to the device order, with a range of slave addresses from 1 to 15. Bit5 to Bit8 are fixed to 0.

(As shown in Table 4)

Parallel use address setting: Refer to the table below for the definition of the DIP switch

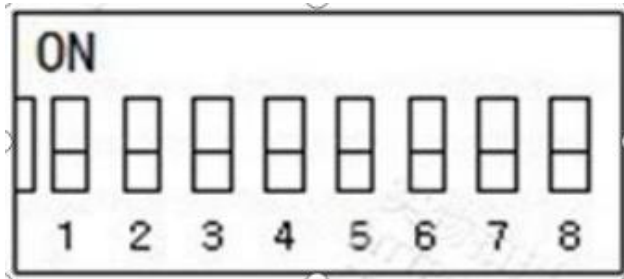

Table 3. Slave Settings

addresses	DIP switch position				instructions
	#1	#2	#3	#4	
1	ON	OFF	OFF	OFF	Pack1
2	OFF	ON	OFF	OFF	Pack2
3	ON	ON	OFF	OFF	Pack3
4	OFF	OFF	ON	OFF	Pack4
5	ON	OFF	ON	OFF	Pack5
6	OFF	ON	ON	OFF	Pack6
7	ON	ON	ON	OFF	Pack7
8	OFF	OFF	OFF	ON	Pack8
9	ON	OFF	OFF	ON	Pack9
10	OFF	ON	OFF	ON	Pack10
11	ON	ON	OFF	ON	Pack11

12	OFF	OFF	ON	ON	Pack12
13	ON	OFF	ON	ON	Pack13
14	OFF	ON	ON	ON	Pack14
15	ON	ON	ON	ON	Pack15

The host setting address dialing method is shown in Table 4

Table 4. host Settings

Number of parallel	DIP switch position				instructions
	#5	#6	#7	#8	
2	ON	OFF	OFF	OFF	2 parallel machines
3	OFF	ON	OFF	OFF	3 parallel machines
4	ON	ON	OFF	OFF	4 parallel machines
5	OFF	OFF	ON	OFF	5 parallel machines
6	ON	OFF	ON	OFF	6 parallel machines
7	OFF	ON	ON	OFF	7 parallel machines
8	ON	ON	ON	OFF	8 parallel machines
9	OFF	OFF	OFF	ON	9 parallel machines
10	ON	OFF	OFF	ON	10 parallel machines

11	OFF	ON	OFF	ON	11 parallel machines
12	ON	ON	OFF	ON	12 parallel machines
13	OFF	OFF	ON	ON	13 parallel machines
14	ON	OFF	ON	ON	14 parallel machines
15	OFF	ON	ON	ON	15 parallel machines
16	ON	ON	ON	ON	16 parallel machines

Example of parallel dialing code setting is shown in Table 5

Table 5 Example of parallel dialing code setting

Number of parallel	DIP switch position								instructions
	#1	#2	#3	#4	#5	#6	#7	#8	
Single machine use	OFF	OFF	OFF	OFF	OFF	OFF	OFF	OFF	Single machine use
2 parallel machines	OFF	OFF	OFF	OFF	ON	OFF	OFF	OFF	host machine
	ON	OFF	OFF	OFF	OFF	OFF	OFF	OFF	First slave machine
3 parallel machine	OFF	OFF	OFF	OFF	OFF	ON	OFF	OFF	host machine
	ON	OFF	OFF	OFF	OFF	OFF	OFF	OFF	First slave machine

s	OFF	ON	OFF	OFF	OFF	OFF	OFF	OFF	Second slave machine
⋮	⋮	⋮	⋮	⋮	⋮	⋮	⋮	⋮	⋮
⋮	⋮	⋮	⋮	⋮	⋮	⋮	⋮	⋮	⋮
16 parallel machines	OFF	OFF	OFF	OFF	ON	ON	ON	ON	First host machine
	ON	OFF	OFF	OFF	OFF	OFF	OFF	OFF	Second slave machine
	OFF	ON	OFF	OFF	OFF	OFF	OFF	OFF	third slave machine
	ON	ON	OFF	OFF	OFF	OFF	OFF	OFF	forth slave machine
	OFF	OFF	ON	OFF	OFF	OFF	OFF	OFF	Fifth slave machine
	ON	OFF	ON	OFF	OFF	OFF	OFF	OFF	Sixth slave machine
	OFF	ON	ON	OFF	OFF	OFF	OFF	OFF	Seventh slave machine
	ON	ON	ON	OFF	OFF	OFF	OFF	OFF	eighth slave machine
	OFF	OFF	OFF	ON	OFF	OFF	OFF	OFF	ninth slave machine

	ON	OFF	OFF	ON	OFF	OFF	OFF	OFF	tenth slave machine
	OFF	ON	OFF	ON	OFF	OFF	OFF	OFF	Eleventh slave machine
	ON	ON	OFF	ON	OFF	OFF	OFF	OFF	twelfth slave machine
	OFF	OFF	ON	ON	OFF	OFF	OFF	OFF	13th slave machine
	ON	OFF	ON	ON	OFF	OFF	OFF	OFF	14th slave machine
	OFF	ON	ON	ON	OFF	OFF	OFF	OFF	15th slave machine
	ON	ON	ON	ON	OFF	OFF	OFF	OFF	16th slave machine

(5) After the installation of the battery system, pay attention to the insulation treatment of the battery poles and cover the insulation cover.

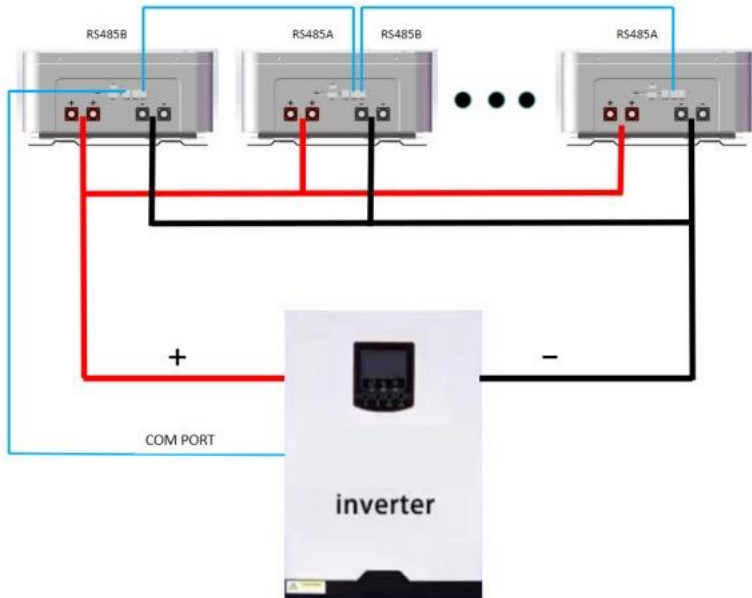

Figure 4: Schematic diagram of parallel operation

4.4 Definition of communication line pins

Item	Crystal head picture	Serial no.	Definition
		1	RS485_B
		2	RS 485_A
		3	GND_COM
		4	CANH
		5	CANL
		6	GND_COM
		7	RS 485_A
		8	RS485_B

Figure 5: Definition of communication line pins

4.5 Integrated RS485 communication

Integrated RS485 communication with a baud rate of 1920bps. The RS485 communication interface adopts an 8P8C network cable interface. RS485 communication interface definition:

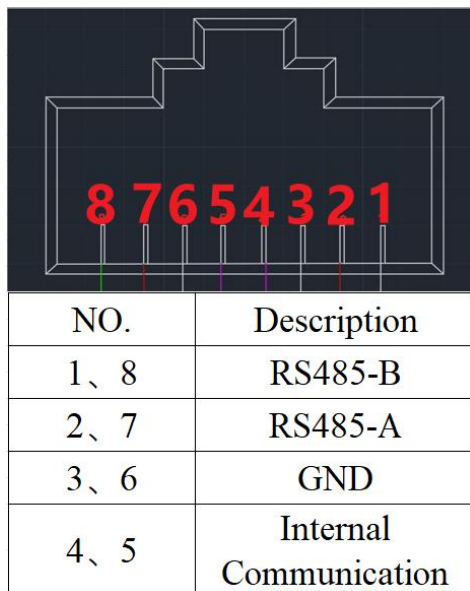

Figure 6: Definition of Centralized Communication Interface

4.6 Wall-mounted battery fixed installation

First, use expansion screws to fix the hanging bracket to the wall, and the battery is hung on the wall through the hanging point, as shown in Figure

7

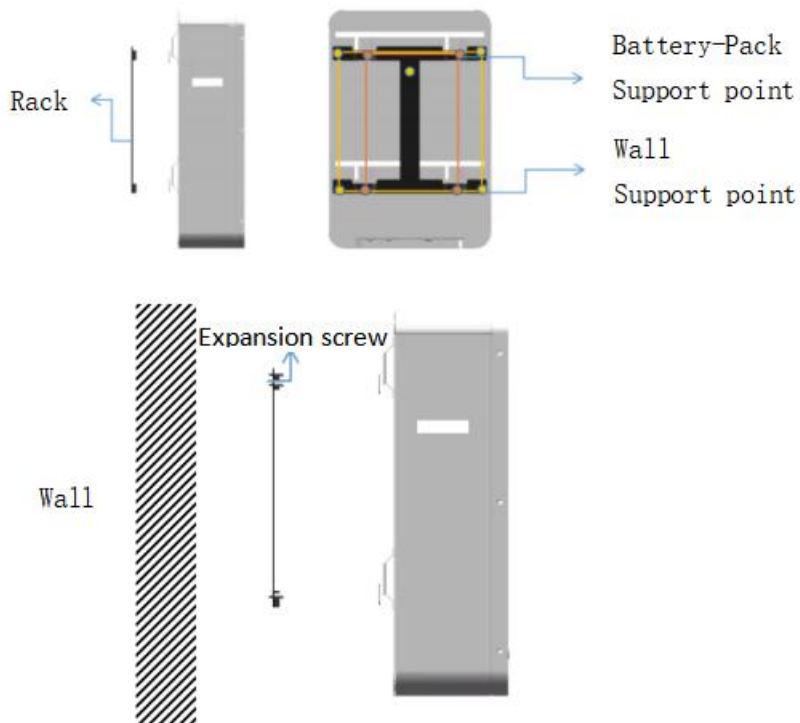

Figure 7: Schematic diagram of fixed installation of chassis

4.7 Switching on and running

4.7.1 Power on/startup

When the BMS is in sleep mode, press the ship type switch ON, the BMS will be started, and the LED indicator lights will flash one by one before entering normal working mode.

4.7.2 Shutdown/Hibernation

When the BMS is in standby or discharge mode, press the ship type switch OFF to put the BMS into sleep mode. After the LED indicator lights flash one by one, it enters sleep mode. BMS has no power consumption after sleep.

4.7.3 Status display

When the battery is in different operating modes, the LED lights on the panel will emit different indications,

system state	running state	run	ALM	SOC				instructions
		●	●	L4●	L3●	L2●	L1●	
Shutdown	hibernate	turn off	turn off	turn off	turn off	turn off	turn off	Total extinction
Standby	normal	Flash 1	turn off	turn off	turn off	turn off	turn off	position in readiness
charge	normal	light	turn off	Always on according to battery indicator				highest LED Flash 2
	Overcurrent alarm	light	Flash 2	Always on according to battery indicator				
	Overvoltage alarm	Flash 1	turn off	turn off	turn off	turn off	turn off	

	Temperature, over current protection	Flash 1	Flash 1	turn off	turn off	turn off	turn off	
discharge	normal	Flash 3	turn off	Always on according to battery indicator				The indicator always lights up according to the battery level
	alarm	Flash 3	Flash 3					
	Temperature, over current, short circuit, etc. protection	turn off	light	turn off	turn off	turn off	turn off	Stop discharging, no action after 48 hours when the mains power is offline, forced to sleep
	under voltage protection	turn off	turn off	turn off	turn off	turn off	turn off	Stop discharging

Figure 8. Running status

The flashing instructions are as follows table 7

Table 6. Capacity Display Status

Flashing mode	light	turn off
Flash 1	0.25s	3.75s
Flash 2	0.5s	0.5s
Flash 3	0.5s	1.5s

The flashing instructions are as follows:

state		charge				discharge			
Capacity indicator light		L4●	L3●	L2●	L1●	L4●	L3●	L2●	L1●
remaining capacity	0~25%	Turn off	Turn off	Turn off	Flash	Turn off	Turn off	Turn off	light
	25~50%	Turn off	Turn off	Flash	light	Turn off	Turn off	light	light
	50~75%	Turn off	Flash	light	light	Turn off	Turn off	light	light
	≥75%	Flash	light	light	light	light	light	light	light
Operation indicator ●		light				Flash			

Figure 9. Explanation of indicator light flashing

4.7.4 Capacity display

Table 7. Capacity Display Status

state		charge				discharge			
Capacity indicator light		L4 ●	L3 ●	L2 ●	L1 ●	L4 ●	L3 ●	L2 ●	L1 ●
remaining capacity	0~25%	Turn off	Turn off	Turn off	Flash	Turn off	Turn off	Turn off	light
	25~50%	Turn off	Turn off	Flash	light	Turn off	Turn off	light	light
	50~75%	Turn off	Flash	light	light	Turn off	light	light	light
	≥75%	Flash	light	light	light	light	light	light	light
Operation indicator ●		light				Flash			

5、 Screen operation instructions

5.1 Screen appearance and buttons as shown in the picture:

(1) Each item starts with a number, where "number flashing" indicates the current cursor position. Pressing the NUM+or NUM - keys can move the cursor position up and down; Press the Enter key to enter the corresponding page. Press the RETURN key to return to the previous level directory.

(2) In sleeping mode, the backlight on the display screen goes out. Press any button to turn on the backlight

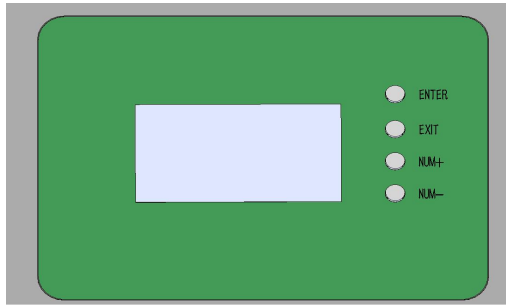

5.2 Interface Introduction

(1) After power on activation, the battery management interface will be displayed, and press the Enter key to enter the main page. As shown in the following figure:



Pack V: Total battery voltage

Current: Current

SOC: Status of capacity

Warn: Alert

(2) Press the NUM key on the battery parameter interface to access detailed battery parameter information



CellV: Cell voltage query

Temperature: Temperature query

Warn: Alarm query

Capacity: Capacity query

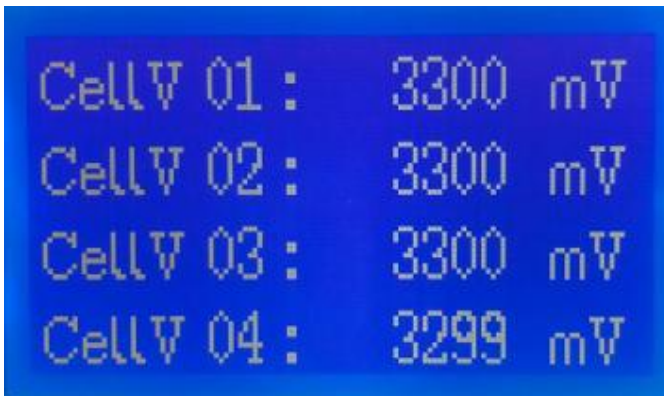

CellV01-CellV16: Cell voltage value

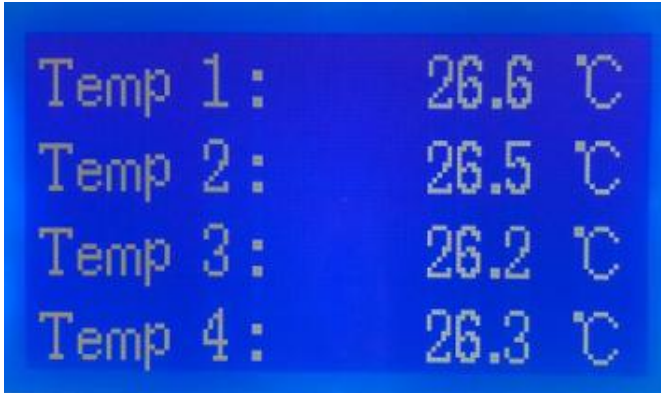

Temp1-Temp4: Cell temperature value



Envir-temp: Ambient temperature

PCB-temp: Power temperature

(3) Status Alarm

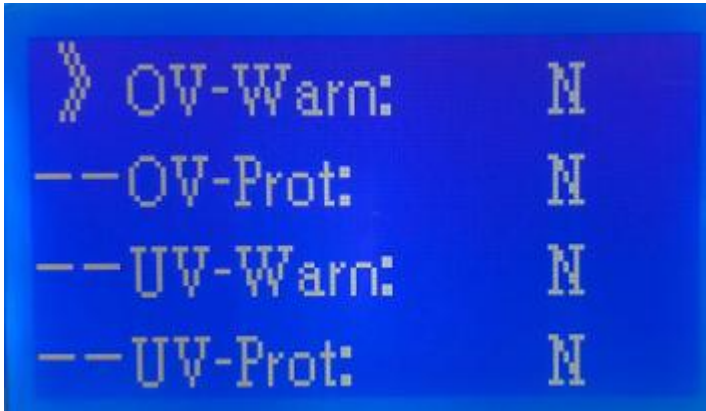

OV-Warn: High voltage warning

OV-Prot: Overvoltage protection

UV-Warn: Low-voltage warning

UV-Prot: Under voltage protection

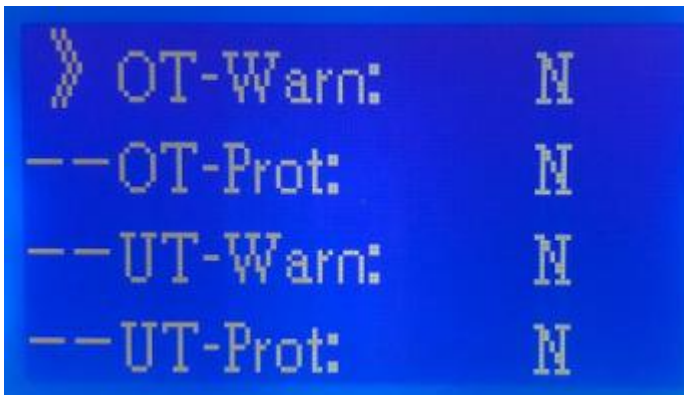

OT-Warn: High temperature warning

OT-Prot: Over temperature protection

UT-Warn: Low temperature warning

UT-Prot: Under-temperature protection

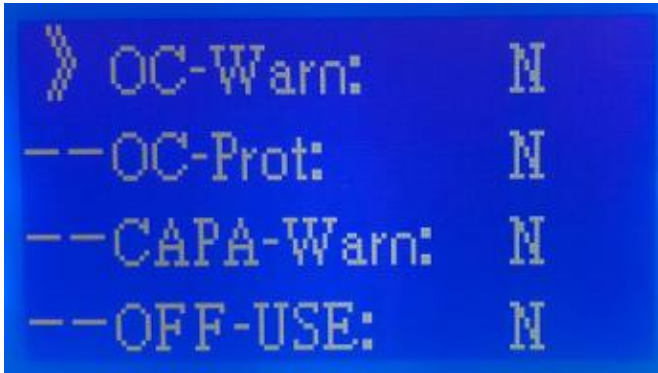

OC-Warn: Over current warning

OC-Prot: Over current protection

CAPA-Warn: Remaining capacity alarm

OFF-USE: Failure warning



SCP: Short circuit protection



FCC: Battery capacity

Rm: The remaining capacity

Cycle Time: Cycles

CAN: CAN protocol

(4) Press the NUM key on the main page to enter the protocol switching interface, select the corresponding protocol, long press the Enter key for 3 seconds, and then switch to SUCCESS. The switch is complete.

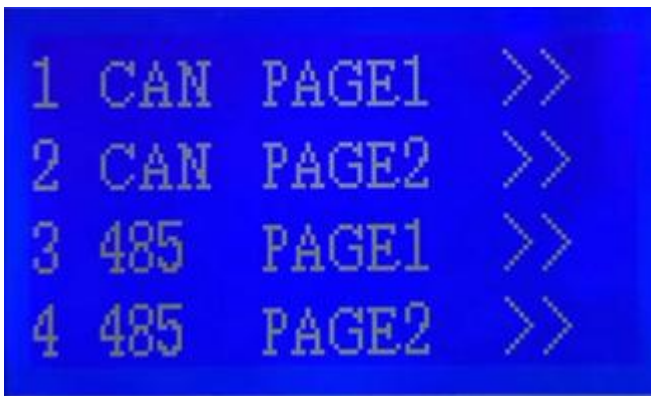



-->CAN PAGE 1

PN GDLT: Pylontech

GRWT: Growatt

VCTR: Victron

SMA SF: SMA



-->CAN PAGE 2

GINL: Ginlong

STUD: Studer

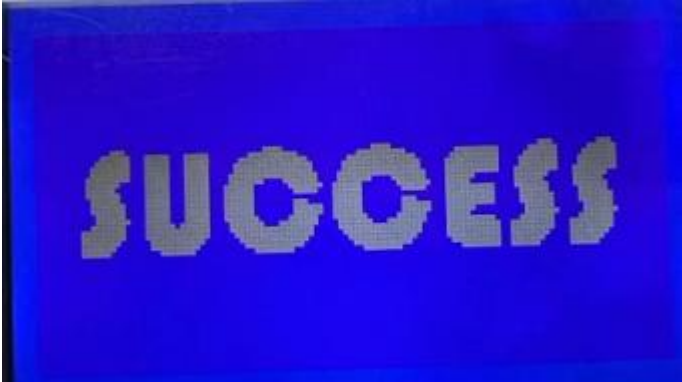

6、 Storage instructions

(1) When storing batteries, it is necessary to ensure that the SOC is $\geq 50\%$;

(2) The battery storage location should be dry and away from the source of goods;

(3) Do not store batteries at high temperatures ($\geq 45\text{ }^{\circ}\text{C}$);

(4) If the battery needs to be stored for a long time, it should be recharged at least once every six months

7、 Declaration

7.1 Due to product version upgrades or other reasons, the content of this document will be updated from time to time. Unless otherwise agreed, this document is for instructional purposes only. All statements, information, and advice in this document do not constitute any express or implied warranties.

7.2 Before installing the equipment, please read the user manual carefully to understand product information and safety precautions.

7.3 All installation operations of the equipment must be performed by trained and qualified electrical technicians. Operators must wear personal protective equipment.

7.4 Before installing the equipment, please check the delivery items according to the "Packing List" to ensure that all the items are complete and intact, without any obvious external damage. If anything is missing or damaged, please contact your dealer.

7.5 Equipment damage caused by failure to operate according to the document is not covered under the equipment warranty.

7.6 The cable colors mentioned in this document are for reference only, and the selection of cables should comply with local cable standards.